

REVISION HISTORY			
REV	DESCRIPTION	DATE	APPROVED
G	ZNU SPEC CHANGE	02/09/21	02/09/21

MATERIAL FINISH	
<b>MATERIAL: 6061-T6 ALUMINUM, UNLESS NOTED</b>	
<b>B</b>	<b>CADMIUM / OLIVE DRAB (NOT FOR NEW DESIGNS RECOMMEND NF)</b>
<b>C*</b>	<b>ANODIZE / BLACK</b>
<b>G*</b>	<b>HARD COAT</b>
<b>J</b>	<b>GOLD IRIDITE OVER CADMIUM PLATE OVER NICKEL</b>
<b>LF</b>	<b>CADMIUM PLATE / BRIGHT OVER ELECTROLESS NICKEL</b>
<b>M</b>	<b>ELECTROLESS NICKEL PER AMS2404 CLASS 4</b>
<b>N</b>	<b>CADMIUM PLATE / OLIVE DRAB OVER NICKEL (NOT FOR NEW DESIGNS RECOMMEND NF)</b>
<b>P2</b>	<b>NICKEL PLATE IAW SAE-AMS-QQ-N-290, CLASS I GRADE D OVER DOUBLE ZINCATE COATING IAW ASTM-B-253</b>
<b>NF</b>	<b>CAD / OD PER AMS-QQ-P-416 TYPE II, CLASS 2 OVER ELECTROLESS NICKEL (500 HR. SALT SPRAY)</b>
<b>NT</b>	<b>NICKEL / TEFLON-CONSULT FACTORY FOR DETAILS</b>
<b>T</b>	<b>CADMIUM PLATE / BRIGHT DMP OVER NICKEL</b>
<b>U**</b>	<b>CADMIUM PLATE / BLACK</b>
<b>Z1**</b>	<b>PASSIVATE SS</b>
<b>ZN</b>	<b>ZINC NICKEL / OD OVER ELECTROLESS NICKEL</b>
<b>ZNU</b>	<b>ALUMINUM / ZINC-NICKEL WITH BLACK CHROMATE PER ASTM B841-18, TYPE D</b>
<b>NTK</b>	<b>NICKEL / TEFLON-1,000HRS SALT FOG, 336HRS SO2</b>
<b>XM***</b>	<b>ELECTROLESS NICKEL OVER COMPOSITE</b>
<b>XW***</b>	<b>CAD/OD OVER ELECTROLESS NICKEL COMPOSITE</b>

\* NON-CONDUCTIVE FINISH- NOT SUITABLE FOR EMI/RFI APPLICATIONS.

\*\* APPLICABLE TO CORROSION RESISTING STEEL BACKSHELLS AND ACCESSORIES.

\*\*\* FOR COMPOSITE BACKSHELL COUPLING NUT SPECIFICATIONS SEE PAGE 2.

CONSULT FACTORY FOR ROHS COMPLIANT FINISHES.

	NAME	DATE
DRAFTER	J. MANGUS	10/18/17
TOLERANCE: {UNLESS OTHERWISE NOTED}		
2 PLACE DEC ±.030		
3 PLACE DEC ±.015		
ANGULAR = ± 2°		
UNLESS OTHERWISE SPECIFIED DIMENSIONS ARE IN INCHES		



ISO 1000  
 7706 E. OSIE - WICHITA, KS. 67207  
 www.isodyneinc.com  
 CAGE CODE # 031M6

**TABLE I**

SHELL SIZE FOR CONNECTOR DESIGNATOR					A THREAD REF	B DIA MAX	C DIA MAX	D FLATS REF
A	F/L	G	H	U				
-	08 09	-	-	-	7/16-28 UNEF	.59 (15.0)		
-	-	-	09 A	-	M12 x 1 - 6H	.65 (16.5)	.86 (21.8)	.75 (19.1)
08	-	-	-	-	1/2-20 UNF	.65 (16.5)		
-	-	-	-	08 9 A B	1/2-28 UNEF	.65 (16.5)		
03	10 11	-	-	-	9/16-24 UNEF	.72 (18.3)	.98 (24.9)	.88 (22.2)
-	-	-	11 B	-	M15 x 1 - 6H	.77 (19.6)		
10	-	-	-	-	5/8-24 UNEF	.77 (19.6)		
-	-	-	-	10 11 C D	5/8-28 UN	.77 (19.6)		
-	12 13	-	-	-	11/16-24 UNEF	.84 (21.3)	1.16 (29.4)	1.00 (25.4)
-	-	-	13 C	-	M18 x 1 - 6H	.89 (22.6)		
12 7	-	11 A	-	-	3/4-20 UNEF	.91 (23.1)		
-	-	-	-	12 13 F	3/4-28 UNS	.91 (23.1)		
-	14 15	-	-	-	13/16-20 UNEF	.97 (24.6)	1.28 (32.5)	1.13 (28.6)
-	-	-	15 D	-	M22 x 1 - 6H	1.03 (26.2)		
14 12	-	13 B	-	-	7/8-20 UNEF	1.03 (26.2)		
-	-	-	-	14 15 G H	7/8-28 UN	1.03 (26.2)		
-	16 17	-	-	-	15/16-20 UNEF	1.09 (27.7)	1.41 (35.7)	1.25 (31.8)
-	-	-	17 E	-	M25 x 1 - 6H	1.15 (29.2)		
16 19	-	15 C	-	-	1-20 UNEF	1.15 (29.2)		
-	-	-	-	16 17 J K	1-28 UN	1.15 (29.2)		
18 27	18 19	-	-	-	1-1/16-18 UNEF	1.22 (31.0)	1.52 (38.5)	1.38 (35.1)
-	-	-	19 F	-	M28 x 1 - 6H	1.28 (32.5)		
-	-	-	17 D	-	1-1/8-18 UNEF	1.28 (32.5)		
-	-	-	-	18 19 M N	1-1/8-28 UN	1.28 (32.5)		
20 37	20 21	-	-	-	1-3/16-18 UNEF	1.34 (34.0)	1.64 (41.7)	1.50 (38.1)
-	-	-	21 G	-	M31 x 1 - 6H	1.41 (35.8)		
-	-	-	19 E	-	1-1/4-18 UNEF	1.41 (35.8)		
-	-	-	-	20 21 P R	1-1/4-28 UN	1.41 (35.8)		
22	22 23	-	-	-	1-5/16-18 UNEF	1.47 (37.3)	1.77 (44.9)	1.63 (41.3)
-	-	-	23 H	-	M34 x 1 - 6H	1.53 (38.9)		
-	-	-	-	22 23 S T	1-3/8-28 UN	1.53 (38.9)		
24	24 25	23 F	-	-	1-7/16-18 UNEF	1.59 (40.4)	1.89 (48.0)	1.75 (44.5)
-	-	-	25 J	-	M37 x 1 - 6H	1.66 (42.2)		
61	-	-	-	-	1-1/2-18 UNEF	1.66 (42.2)		
-	-	-	-	24 25 U M	1-1/2-28 UN	1.66 (42.2)	2.02 (51.2)	1.88 (47.6)
-	-	25 G	-	-	1-9/16-18 UNEF	1.66 (42.2)		
28	-	-	-	-	1-3/4-18 UNS	1.97 (50.0)	2.16 (54.8)	2.00 (50.8)

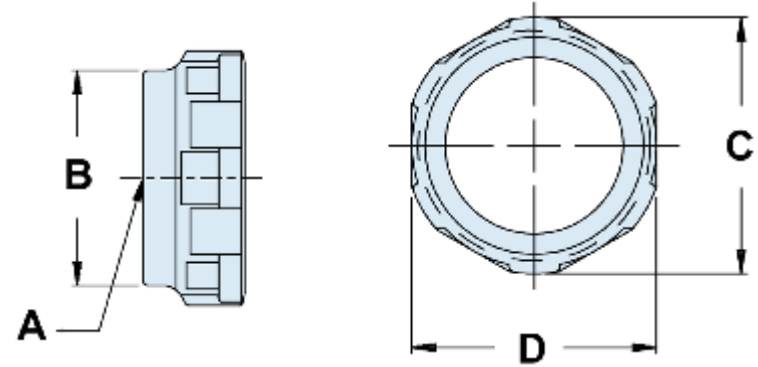

PAGE 2 ONLY APPLICABLE TO COMPOSITE BACKSHELLS. FOR STANDARD BACKSHELL DIMENSIONS REFER TO APPROPRIATE SERIES DRAWING.

METRIC DIMENSIONS (mm) ARE IN PARENTHESES AND ARE REFERENCE ONLY.

	NAME	DATE
DRAFTER	J. MANGUS	10/18/17

TOLERANCE: {UNLESS OTHERWISE NOTED}  
 2 PLACE DEC ± .030  
 3 PLACE DEC ± .015  
 ANGULAR = ± 2°  
 UNLESS OTHERWISE SPECIFIED  
 DIMENSIONS ARE IN INCHES



ISO 1000  
 7706 E. OSIE - WICHITA, KS. 67207  
 www.isodyneinc.com  
 CAGE CODE # 031M6