

DRAWING ISO 165 REV. "K"

QUICK REFERENCE TABLE

SHELL SIZE SEE TABLE IV	H	E REF	G REF	H MAX	MAX ENTRY DES. A	MAX ENTRY DES. F,H,L
08	09	0.390	1.442	1.832	02, 31	02, 31
10	11	0.420	1.472	1.912	03, 32	03, 32
12	13	0.440	1.492	1.972	04, 33	04, 33
14	15	0.460	1.522	2.032	04, 34	05, 34
16	17	0.480	1.542	2.092	05, 35	06, 35
18	19	0.500	1.552	2.112	06, 35	07, 36
20	21	0.520	1.572	2.182	07, 36	08, 37
22	23	0.550	1.612	2.242	08, 37	09, 38
24	25	0.570	1.642	2.262	09, 38	10, 38
28		0.790	1.812	2.402	11, 38	N/A

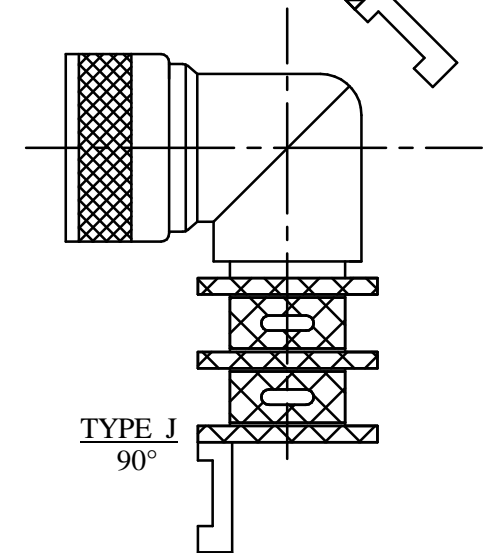
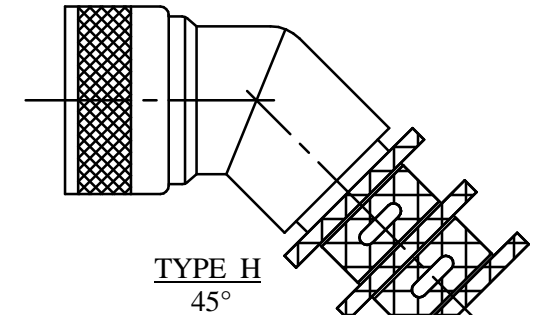
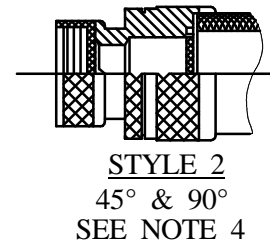
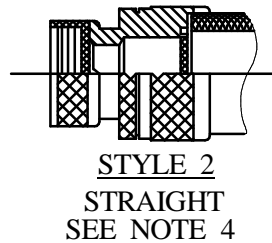
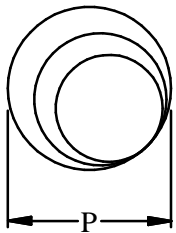
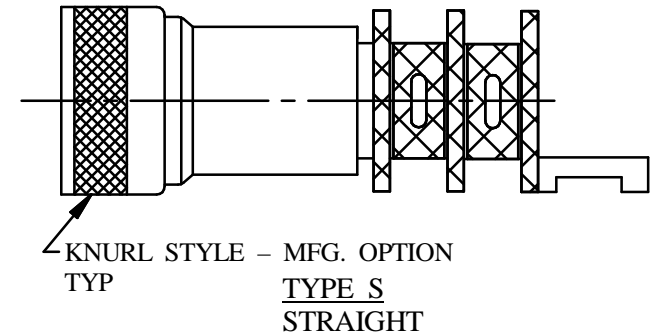

SPRING BAND DIMENSIONS

PART #	P	N	CABLE ENTRY
ISO - 100	0.36	0.37	02 THRU 33
ISO - 200	0.57	0.37	04 THRU 36
ISO - 400	0.78	0.37	07 THRU 09
ISO - 500	0.98	0.37	10 THRU 12
ISO - 600	1.25	0.37	13 THRU 16

PART NUMBER BREAKOUT

EXAMPLE:

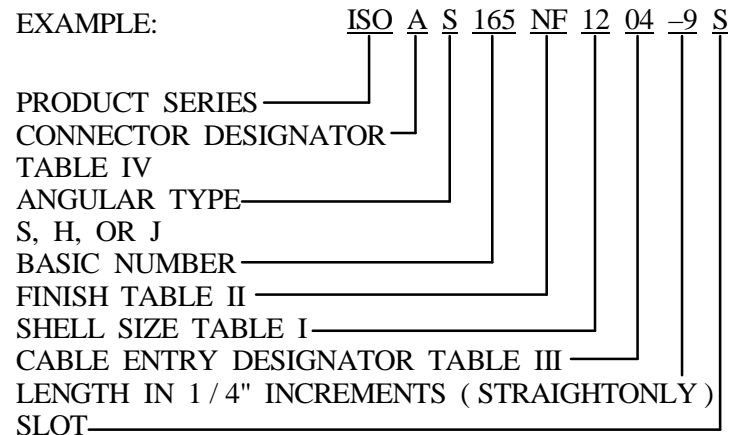

TOLERANCE: {Unless otherwise noted}

2 PLACE DEC ± .030

3 PLACE DEC ± .015

ANGULAR ± 2°

(ALL BACKSHELLS INCLUDE SPRING)

ISODYNE INC

7706 E. OSIE - WICHITA, KS. 67207

U.S. PATENT # 5,769,665

CAGE CODE # 031M6

BACKSHELL, EMI / RFI
 SPRING BAND QUICK TIE STRAIN RELIEF

DRAWING ISO 165 REV. "K"

SHELL SIZE TABLE											TABLE I				
A	C*	D	E	F	G	H	J	K	L	S	A THREAD REF.	B DIA. MAX.	C DIA. MAX.	D DIA. MAX.	E DIA. MAX.
		8	8	8/[9]				8	8	8	7/16—28 UNF	.59 (15.0)	.65 (16.5)	.77 (19.6)	.69 (17.5)
						9/A					M12 X 1—6H	.65 (16.5)	.77 (19.6)		.94 (24.8)
8											1/2—20 UNF	.65 (16.5)	.65 (16.5)		.69 (17.5)
							8/A	10			1/2—28 UNEF	.65 (16.5)	.77 (19.6)	.77 (19.6)	
3		10	10	10/[11]				11	10	10	9/16—24 UNEF	.72 (18.3)	.77 (19.6)	.89 (22.6)	.82 (20.8)
						11/B					M15 X 1—6H	.77 (19.6)	.82 (20.8)		1.06 (26.9)
10								12,13			5/8—24 UNEF	.77 (19.6)	.77 (19.6)	.89 (22.6)	.82 (20.8)
						10/B					5/8—28 UN	.77 (19.6)	.89 (22.6)		
		12		12/[13]					12	12	11/16—24 UNEF	.84 (21.3)	.89 (22.6)	1.02 (25.9)	.94 (23.8)
						13/C					M18 X 1—6H	.89 (22.6)	.94 (23.9)		1.17 (29.7)
12/7	12		12		11/A			14,15			3/4—20 UNEF	.91 (23.1)	.89 (22.6)	1.02 (25.9)	.94 (23.8)
									14	14	3/4—20 UNF		.94 (23.9)		
		14	14	14/[15]							13/16—20 UNEF	.97 (24.6)	1.02 (25.9)	1.15 (29.2)	1.06 (26.9)
						15/D					M22 X 1—6H	1.03 (26.2)	1.07 (27.2)		1.29 (32.7)
14/12	14				13/B			16,17			7/8—20 UNEF	1.03 (26.2)	1.02 (25.9)	1.15 (29.2)	1.06 (26.9)
											7/8—20 UNF		1.07 (27.2)		
							14/D				7/8—20 UN	1.03 (26.2)	1.15 (29.2)		
		16	16	16/[17]					16	16	15/16—20 UNEF	1.09 (27.7)	1.15 (29.2)	1.26 (32.0)	1.17 (29.7)
						17/E					M25 X 1—6H	1.15 (29.2)	1.21 (30.7)		1.42 (36.1)
16/19	16				15/C			18			1—20 UNEF	1.15 (29.2)	1.15 (29.2)	1.23 (32.2)	1.17 (29.7)
											1—20 UNF		1.21 (30.7)		
						16/E					1—28 UN	1.15 (29.2)	1.36 (34.5)		
18/27		18	18	18/[19]					18	18	1—1/16—18 UNEF	1.22 (31.0)	1.23 (31.2)	1.40 (35.6)	1.29 (32.7)
						19/F					M28 X 1—6H	1.28 (32.5)	1.36 (34.5)		1.54 (39.1)
	18				17/D			20			1—1/8—18 UNEF	1.28 (32.5)	1.41 (35.7)	1.36 (34.5)	
											1—1/8—28 UN	1.28 (32.5)	1.48 (37.6)		
20/37		20	20	20/[21]					20	20	1—3/16—18 UNEF	1.34 (34.0)	1.36 (34.5)	1.53 (38.9)	1.42 (36.0)
						21/G					M31 X 1—6H	1.41 (35.8)	1.48 (37.6)		1.67 (42.4)
	20				19/E			22			1—1/4—18 UNEF	1.41 (35.8)	1.53 (38.9)	1.48 (37.6)	
							20/G				1—1/4—28 UN	1.41 (35.8)	1.60 (40.6)		
22		22	22	22/[23]					22	22	1—5/16—18 UNEF	1.47 (37.3)	1.48 (37.6)	1.60 (40.6)	1.54 (39.1)
						23/H					M34 X 1—6H	1.53 (38.9)	1.60 (40.6)		2.01 (51.1)
								24			1—3/8—18 UNEF	1.53 (38.9)		1.60 (40.6)	
						22/H					1—3/8—28 UN	1.53 (38.9)	1.73 (43.9)		
24		24	24	24/[25]	23/F				24	24	1—7/16—18 UNEF	1.59 (40.4)	1.60 (40.4)	1.94 (49.3)	1.66 (42.4)
						25/J					M37 X 1—6H	1.66 (42.4)	1.70 (43.2)		2.12 (53.8)
61											1—1/2—18 UNEF	1.66 (42.4)	1.67 (42.4)		
											1—1/2—28 UN	1.66 (42.4)	1.94 (49.3)		
					25/G						1—9/16—18 UNEF		1.82 (46.3)		
	24							28			1—5/8—18 UNEF	1.84 (46.7)		1.94 (49.3)	
28											1—3/4—18 UNS	1.97 (50.0)	1.97 (50.0)		2.01 (51.1)
	28				29/H			32			1—7/8—16 UN	2.09 (53.1)	2.19 (55.6)	2.19 (55.6)	
32											2—18 UNS	2.28 (57.9)	2.22 (58.4)		2.26 (57.4)
	32				33/J						2—1/16—16 UNS		2.44 (62.0)	2.44 (62.0)	
								36			2—1/8—16 UN	2.34 (59.4)		2.44 (62.0)	
36											2—1/4—16 UN	2.53 (64.3)	2.47 (62.7)		2.53 (64.3)
	36										2—5/16—16 UNS			2.69 (68.3)	
								40			2—3/8—16 UN	2.59 (65.8)		2.69 (68.3)	
40											2—1/2—16 UN	2.78 (70.6)	2.72 (69.1)		3.04 (77.2)
	40										2—5/8—16 UN			2.93 (74.4)	
44											2—3/4—16 UN	3.03 (77.0)	2.97 (75.4)		
48											3—16 UN	3.22 (81.8)	3.22 (81.8)		

* LEFT HAND THREAD

[] REFERENCE ONLY — NOT USED IN FORMATION OF PART NUMBER

DRAWING ISO 165 REV. "K"

TABLE II - MATL FINISH		TABLE III - CABLE ENTRY DIMENSIONS									TABLE IV - CONNECTOR SERIES			
B	CADMIUM / OLIVE DRAB	CABLE ENTRY DES.	J	K	L	M (±.094)	S (NO. OF SLOTS)	V	U	T RADIUS	CONNECTOR DESIGNATOR	CONNECTOR SPECIFICATION	SERIES	
C*	ANODIZE / BLACK													
G*	HARD COAT											MIL - C - 5015	MS3400	
J	GOLD IRIDITE OVER CADMIUM PLATE OVER NICKEL	01	0.125	0.250	0.450	0.593	(2) .125 ϕ	0.250	0.125	0.062		MIL - C - 26482	II	
		31	0.188	0.312	0.512	0.625	(2) .170 ϕ	0.250	0.125	0.062		MIL - C - 81703	III	
LF	CADMIUM PLATE / BRIGHT OVER ELECTROLESS NICKEL	02	0.250	0.375	0.575	0.656	(2) .170 ϕ	0.250	0.125	0.062		MIL - C - 83723	I & III	
		32	0.312	0.438	0.638	0.687	(2) .170 ϕ	0.281	0.125	0.062	A	DEF 5926 - 3		
M	ELECTROLESS NICKEL	03	0.375	0.500	0.700	0.719	(4) .250	0.310	0.155	0.078		LN 29504		
N	CADMIUM PLATE / OLIVE DRAB OVER NICKEL	33	0.438	0.562	0.762	0.750	(4) .250	0.310	0.155	0.078		NFC 93422		
		04	0.500	0.625	0.825	0.781	(4) .250	0.375	0.219	0.078		PAN 6432 - 1		
NF	CAD / OD OVER ELECTROLESS NICKEL (500 HR. SALT SPRAY)	34	0.562	0.688	0.888	0.812	(4) .250	0.375	0.219	0.078		PAN 6432 - 2		
		05	0.625	0.750	0.950	0.844	(4) .500	0.375	0.219	0.078		PATT 602		
T	CADMIUM PLATE / BRIGHT DMP OVER NICKEL	35	0.688	0.812	1.012	0.875	(4) .500	0.375	0.219	0.078	C	MIL - C - 22992	R ***	
		06	0.750	0.875	1.075	0.906	(4) .500	0.437	0.281	0.078	D	MIL - C - 26482	I	
U**	CADMIUM PLATE / BLACK	36	0.812	0.938	1.138	0.937	(4) .500	0.437	0.281	0.078	E	MIL - C - 26500	ALUM	
ZI**	PASSIVATE SS	07	0.875	1.000	1.200	0.969	(8) .500	0.437	0.281	0.078		MIL - C - 38999	I & II	
ZN	ZINC NICKEL / OD OVER ELECTROLESS NICKEL	37	0.938	1.062	1.262	1.000	(8) .500	0.437	0.281	0.078		4CM38277		
		08	1.000	1.125	1.325	1.031	(8) .500	0.531	0.375	0.078		NFC 93422	HE 309	
NT	NICKEL/TEFLON - CONSULT FACTORY FOR DETAILS	38	1.062	1.188	1.388	1.062	(8) .500	0.531	0.375	0.078	F	NFC 93422	HE 308	
		09	1.125	1.250	1.450	1.094	(8) .500	0.531	0.375	0.078		PAN 6433 - 1		
		10	1.250	1.375	1.578	1.156	(8) .750	0.531	0.375	0.078		PATT 614		
		11	1.375	1.500	1.700	1.219	(8) .750	0.625	0.469	0.078		PATT 616		
		12	1.500	1.625	1.825	1.281	(8) 1.000	0.625	0.469	0.078	G	MIL - C - 28840		
		13	1.625	1.760	1.950	1.344	(8) 1.000	0.625	0.469	0.078	H	MIL - C - 38999	III & IV	
		14	1.750	1.875	2.075	1.406	(8) 1.000	0.750	0.594	0.078		MIL - C - 81511	I & II	
		15	1.875	2.000	2.200	1.469	(8) 1.000	0.750	0.594	0.078	J	MIL - C - 81511	III & IV	
	16	2.000	2.125	2.325	1.531	(8) 1.000	0.750	0.594	0.078		VG 95329			
* NON-CONDUCTIVE FINISH - NOT SUITABLE FOR EMI / RFI SHIELDING APPLICATIONS. ** APPLICABLE TO CORROSION RESISTING STEEL BACKSHELLS AND ACCESSORIES. *** MIN LENGTH 2.00"											K	MIL - C - 83723	II	
													LN 29729	
													NFC - 93422	HE 306
												L	PAN 6433 - 2	
													PATT 615	
													VG 96912	I
												S	PATT 105, 603, 608	
												R	VG 95234	
												X	MIL - C - 81703	II

NOTES:

1. FOR EFFECTIVE GROUNDING, CONNECTOR WITH CONDUCTIVE FINISH SHOULD BE USED.
2. MIN. ORDER LENGTH FOR STYLE 1-1.25(5), TOTAL LENGTH 1.50. FOR STYLE II MIN. ORDER LENGTH -1.50(6), TOTAL LENGTH 1.75.
3. DIMENSIONS E, G, M, H DO NOT APPLY WHEN STYLE II ADAPTER IS APPLIED. NO "O" RING APPLIED, SYMBOL A.
4. WHEN MAX. CABLE ENTRY IS EXCEEDED, STYLE 2 WILL BE SUPPLIED. PLEASE CONSULT FACTORY.
5. NON-MAGNETIC BAND MATERIAL - ELGILOY
6. SUFFIX 770 TO BE USED TO ACCOMADATE LARGE GROMETS LIKE PT_CE CONNECTORS MFG BY AMPHENOL AND CANNON



7706 E. OSIE - WICHITA, KS. 67207
 U.S. PATENT # 5,769,665
 CAGE CODE # 031M6

BACKSHELL, EMI / RFI
 SPRING BAND QUICK TIE STRAIN RELIEF

REVERSE BAYONET

TABLE V		TABLE VI									
CONN-CODE	MANUFACTURE AND SERIES DESCRIPTION	ORDER NO	SHELL SIZE VG95234	CONNECTOR DESIGNATOR	A THREAD CLASS 2B	C MAX	E MAX	G MAX	M MAX	H MAX	MAX ENTRY TABLE III
-	COMMITAL, VG95234 & 95328										
A	AMPHENOL, GT SERIES, VG95234										
B	ITT CANNON, VG95234	10	10SL	-, A, C, D, E	5/8-24 UNEF	1.00	0.982	1.802	1.184	2.006	03
C	LITTON VEAM, CIR SERIES, VG95234	11	10SL	B	9/16-24 UNEF	1.00	0.957	1.779	1.122	1.944	33
D	SPACE CRAFT, VG95234	12	12S	B	5/8-24 UNEF	1.00	0.982	1.802	1.184	2.006	03
E	JTECH, TTCIR, VG95234	14	14S	-, A, B, C, D, E	3/4-20 UNEF	1.13	0.955	1.817	1.215	2.037	04
NOTES: 1. FOR EFFECTIVE GROUNDING, CONNECTOR WITH CONDUCTIVE FINISH SHOULD BE USED. 2. MIN. ORDER LENGTH FOR STYLE I-1.25(5), TOTAL LENGTH 1.50. FOR STYLE II MIN. ORDER LENGTH-1.50(6), TOTAL LENGTH 1.75. 3. DIMENSIONS E, G, M, H, DO NOT APPLY WHEN STYLE II ADAPTER IS APPLIED. NO "O" RING APPLIED, SYMBOL A. 4. WHEN MAX. CABLE ENTRY IS EXCEEDED, STYLE 2 WILL BE SUPPLIED. PLEASE CONSULT FACTORY. 5. NON-MAGNETIC BAND MATERIAL - ELGILOY 6. SUFFIX 770 TO BE USED TO ACCOMODATE LARGE GROMETS LIKE PT_CE CONNECTORS MFG BY AMPHENOL AND CANNON 7. BACKSHELL IS DESIGNED TO ACCOMODATE WIRE SEAL GROMMET AND FOLLOWER SUPPLIED WITH CONNECTOR. 8. ALL REVERSE BAYONET BACKSHELLS HAVE A MIN LENGTH OF 2 INCHES OR -8S		16	16S	-, A, B, C, D, E	7/8-20 UNEF	1.13	1.021	1.843	1.287	2.100	05
		17	16	-, A, B, C, D, E	7/8-20 UNEF	1.25	1.021	1.843	1.287	2.100	05
		18	18	-, A, B, C, D, E	1-20 UNEF	1.38	1.047	1.869	1.340	2.162	06
		20	20	-, A, B, C, D, E	1 1/8-18 UNEF	1.50	1.073	1.895	1.403	2.225	07
		22	22	-, A, B, C, D, E	1 1/4-18 UNEF	1.63	1.099	1.921	1.465	2.287	07
		24	24	-, A, B, C, D, E	1 3/8-18 UNEF	1.75	1.133	1.955	1.548	2.370	38
		28	28	-, A, B, C, D, E	1 5/8-18 UNEF	1.98	1.177	1.999	1.653	2.475	09
		32	32	-, A, B, C, D, E	1 7/8-16 UNEF	2.23	1.229	2.051	1.778	2.600	12
		36	36	-, A, C, D, E	2 1/16-16 UNEF	2.48	1.267	2.089	1.871	2.693	14
		37	36	B	2 1/8-16 UNS	2.48	1.267	2.089	1.871	2.693	14
39	40	B	2 3/8-16 UNS	2.73	1.332	2.154	2.028	2.850	16		
40	40	-, A, C, D, E	2 5/16-16 UNS	2.73	1.332	2.154	2.028	2.850	16		

EXAMPLE:

ISO R S 165 NF 12 04 -8 S C -N

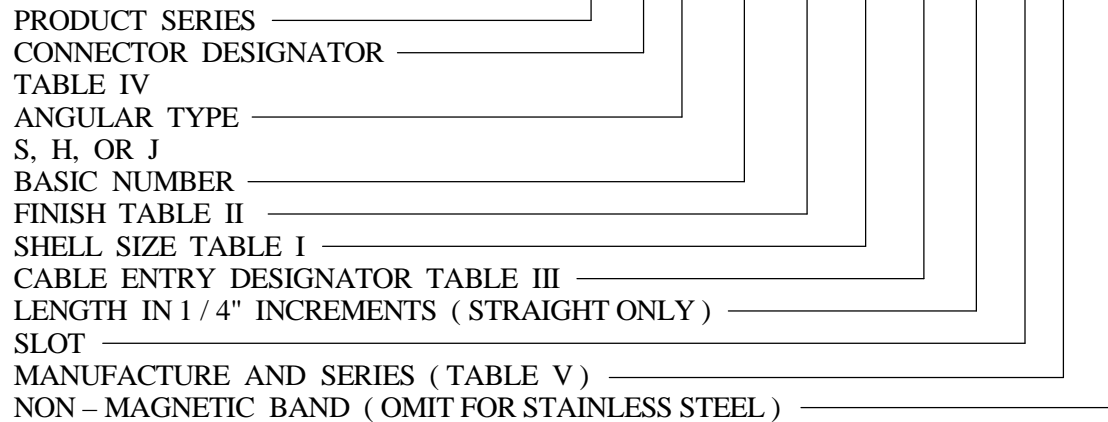

7706 E. OSIE - WICHITA, KS. 67207
 U.S. PATENT # 5,769,665
 CAGE CODE # 031M6

BACKSHELL, EMI / RFI
 SPRING BAND QUICK TIE STRAIN RELIEF

DRAWING ISO 165 REV. "K"

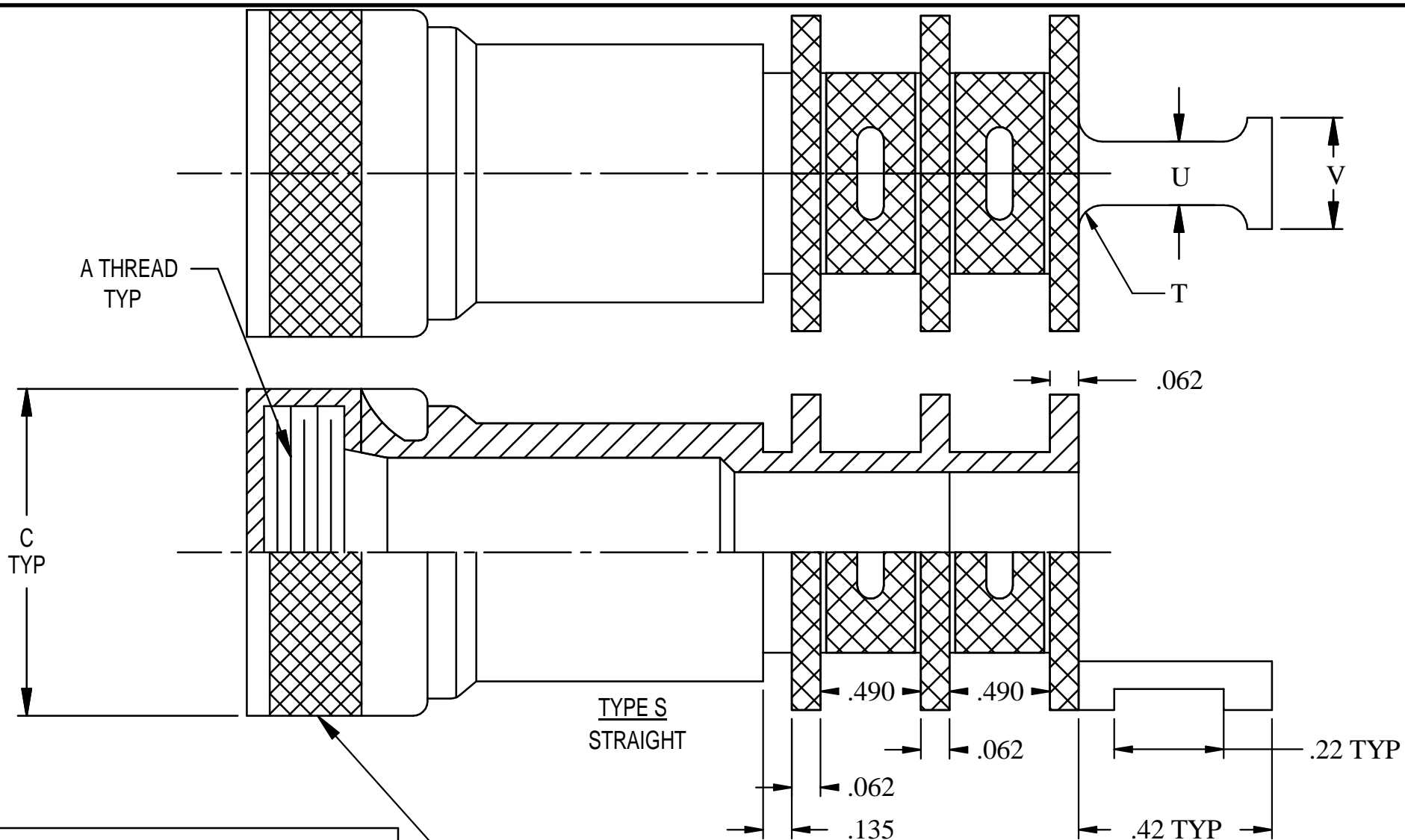

A THREAD
TYP

C
TYP

TYPE S
STRAIGHT

TYP, KNURL STYLE - MFG. OPTION

.062

.490

.490

.22 TYP

.062

.135

.42 TYP

U

V

T

ISODYNE INC

7706 E. OSIE - WICHITA, KS. 67207

U.S. PATENT # 5,769,665

CAGE CODE # 031M6

BACKSHELL, EMI / RFI
SPRING BAND QUICK TIE STRAIN RELIEF

NOTE: For dimensions not shown
see ISO 160 Page 5

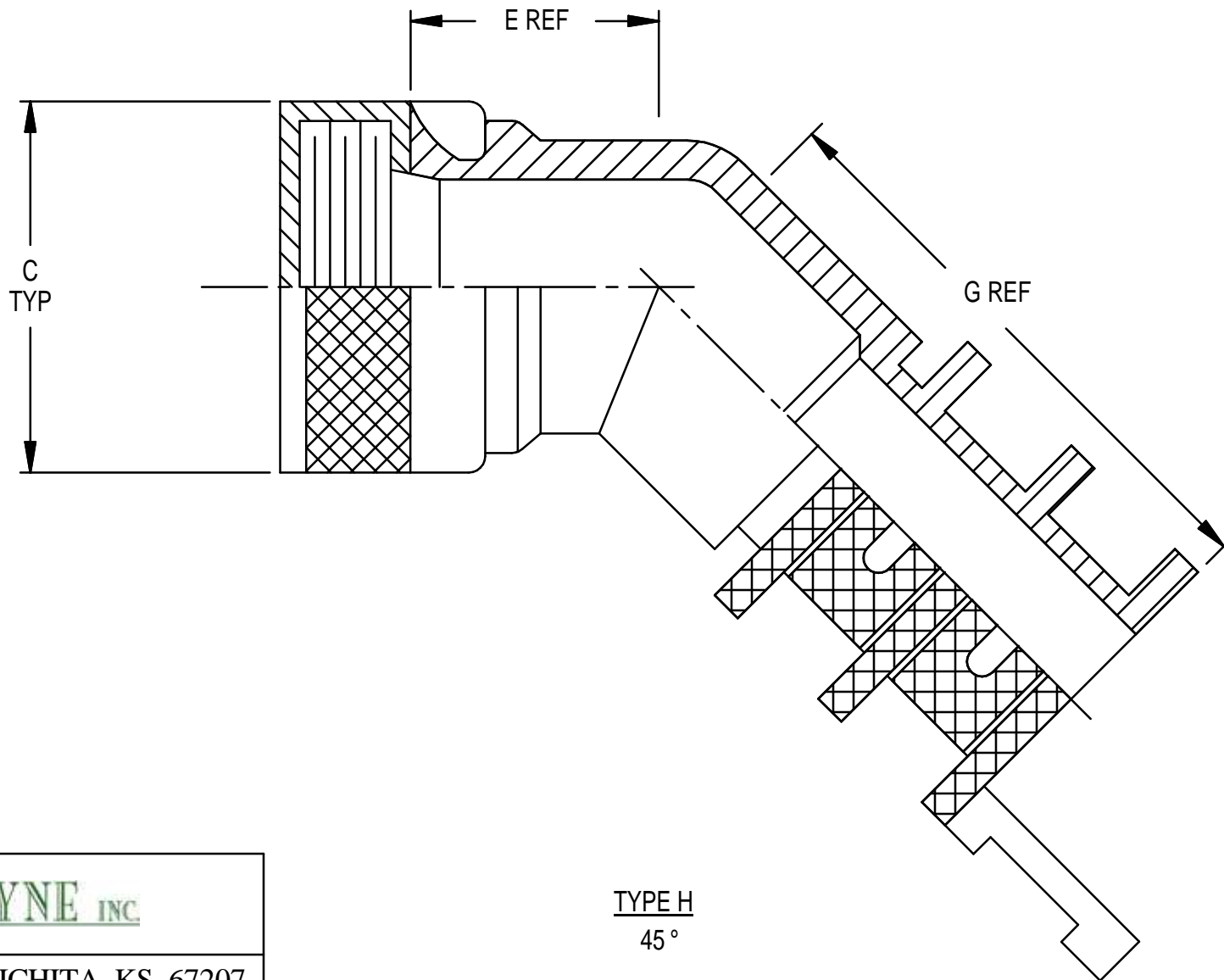

ISODYNE INC

7706 E. OSIE - WICHITA, KS. 67207

U.S. PATENT # 5,769,665

CAGE CODE # 031M6

BACKSHELL, EMI / RFI
SPRING BAND QUICK TIE STRAIN RELIEF

TYPE H
45°

NOTE: For dimensions of quick tie
strain relief, see page 5.

DRAWING ISO 165 REV. "K"

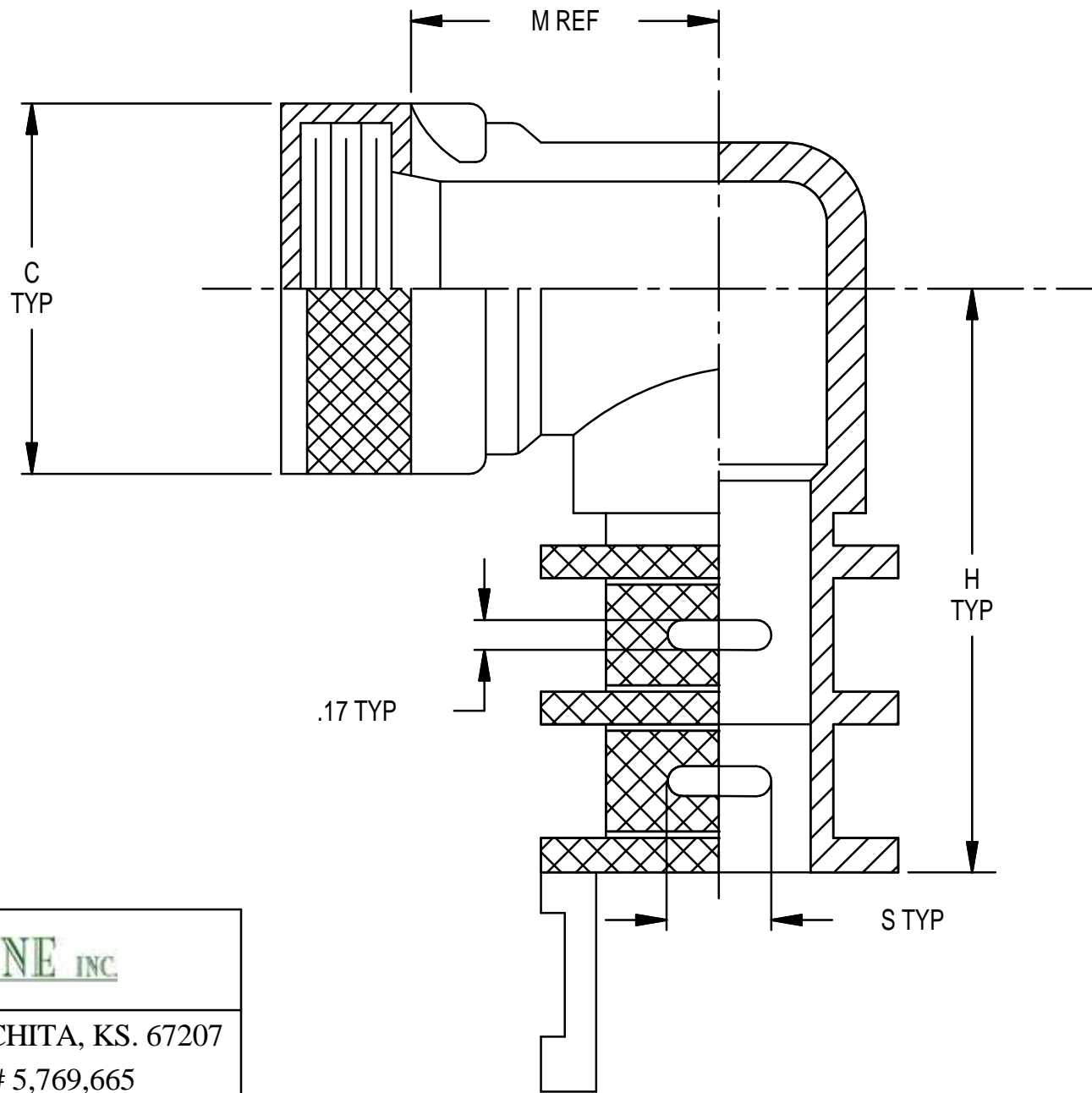

NOTE: For dimensions of quick tie strain relief, see page 5

ISODYNE INC

7706 E. OSIE - WICHITA, KS. 67207

U.S. PATENT # 5,769,665

CAGE CODE # 031M6

BACKSHELL, EMI / RFI
SPRING BAND QUICK TIE STRAIN RELIEF